

Hy-Lite Remote Alarm Module

Model RMA

When visual and audible indication of changing water quality is necessary at a separate location, Hy-Lite Resistivity Indicators can be connected to the Hy-Lite Remote Alarm Module.

With its own green/red LED's and peizo alarm, the module acts as a repeater. The circuit and alarm are housed in a wall mountable enclosure. The electronic membrane overlay front label contains the LEDs, and an alarm silence switch.



The Remote Alarm Module can be installed at distances **up to 700 feet!** Connection can be made to either a HLA (alarm) or HLS (non-alarm) model Hy-Lite. Module input and Hy-Lite output ports utilize telephone "handset" connectors for fast and easy, *click-click*, installation. Cables are available in standard 10, 50, 100, & 200 ft lengths. Custom lengths can be ordered, or quickly fabricated on-site with the aid of an appropriate crimping tool.

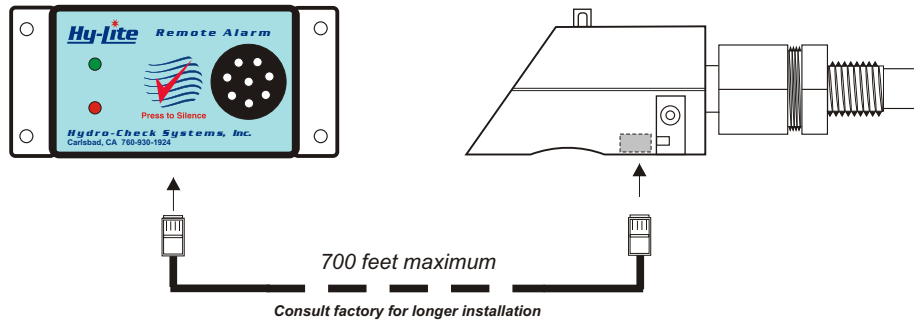

Operational status of the alarm module is identical to the connected Hy-Lite Resistivity Indicator. Whenever the water is of higher purity than the set-point, the green light remains on. Should the water purity fall below set-point, the red light begins flashing, and the 70 dB peizo alarm will sound. The alarm is automatically silenced by the return to a green-light status. It can also be silenced manually during a red light condition by pressing the red "check" symbol on the front label. Once reset manually, the alarm will not resound until the next change from green-to-red. When connected to a Hy-Lite with alarm (HLA), both units act as a system... Silencing the alarm at either location will silence *both* alarms.

Above Set-Point

Steady Green LEDs

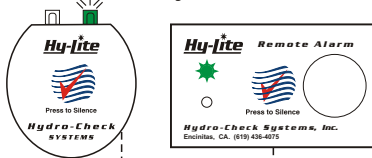

Below Set-Point

Flashing Red LEDs & Audible Alarms

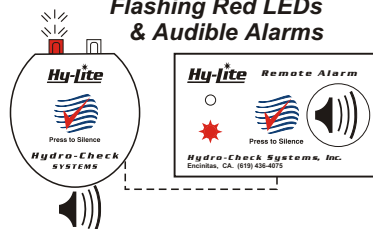

Below Set-Point

After Pressing Either Switch
Flashing Red LEDs

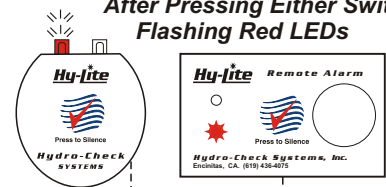

Hydro-Check Systems, Inc

5931 Sea Lion Place, Suite 100, Carlsbad, CA 92008 Voice: 760-930-1924 Fax: 760-930-1934

www.hydrocheck.com