

Hy-Lite Remote Alarm Module

DATA & INSTALLATION, Model RMA

When visual and audible indication of changing water quality is necessary at a separate location, Hy-Lite Resistivity Indicators can be connected to the Hy-Lite Remote Alarm Module.

With its own green/red LED's and peizo alarm, the alarm module acts as a repeater. The circuit and alarm are housed in a wall mountable enclosure. The electronic membrane overlay front label contains the LED's and an alarm silence switch.



The Remote Alarm Module can be installed at distances **up to 700 feet!** Both module input and Hy-Lite output ports utilize telephone "handset" connectors for fast and easy, *click-click*, installation. Cables are available in standard 10, 50, 100 & 200 ft lengths. Custom lengths can be ordered, or quickly fabricated on-site with the aid of an appropriate crimping tool.

Operational status of the alarm module is identical to the connected Hy-Lite Resistivity Indicator. Whenever the water is of higher purity than the set-point, the green light remains on. Should the water purity fall below set-point, the red light begins flashing, and the alarm will sound. The alarm is automatically silenced by the return to a green-light status. It can also be silenced manually during a red light condition by pressing the red "check" symbol on the front label. Once reset manually, the alarm will not resound until the next change from green-to-red. When connected to a Hy-Lite with alarm (HLA), both units act as a system... **Silencing the alarm at either location will silence both alarms.**

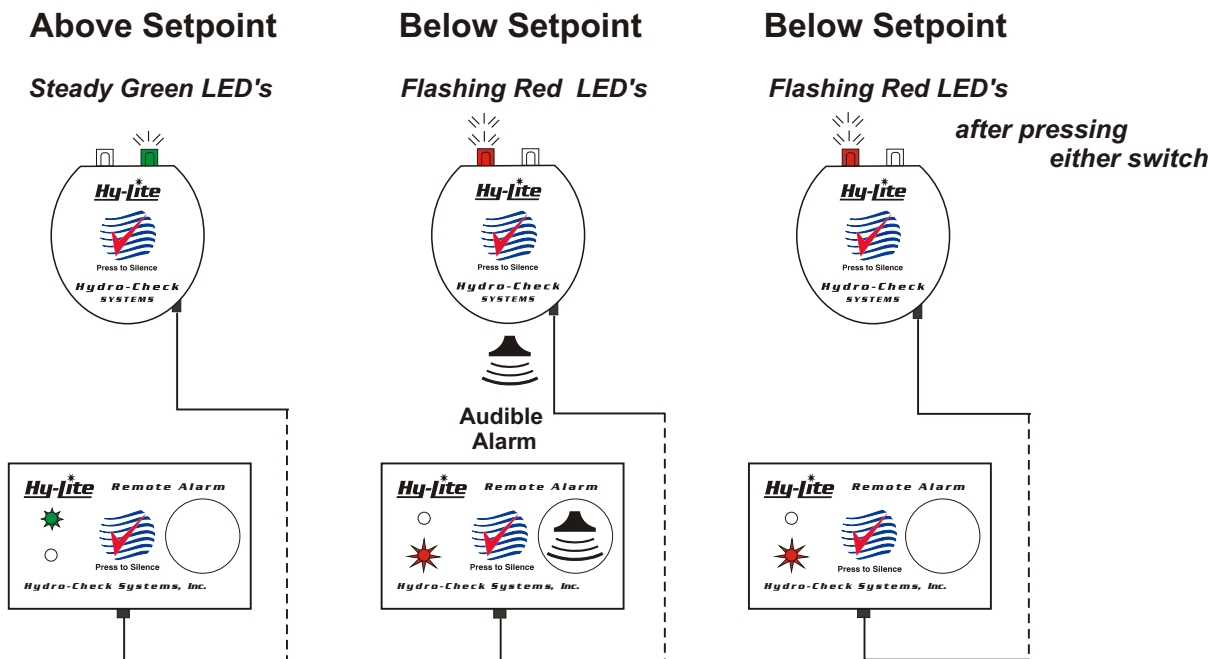

Alarm / Display Modes

Specs:

Display: Steady Green/Flashing Red LED's

Alarm: Peizo-electric with membrane reset switch; in excess of 70 dB @ 3 feet, 4kHz \pm 10%

Enclosure: ABS plastic, 3-1/8" x 2" x 1-3/8" , and 4-3/8" x 2" mounting plate

Signal & Power Supply: Hy-Lite Resistivity Indicator Model HLA or HLS

Interconnection: Flat-oval telephone cable, four wire, 26 gauge, UL 4110 with FCC 68 modular handset connectors

Maximum Cable Length: 700 feet

Installation:

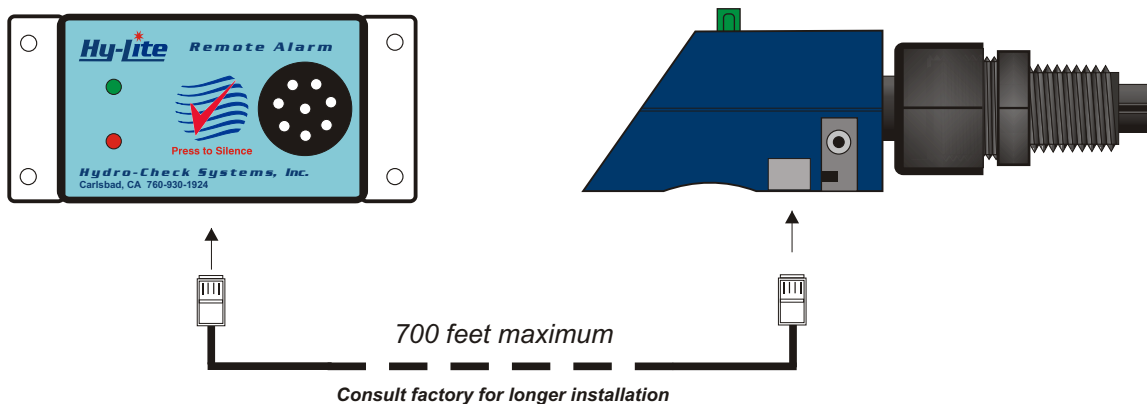

1) Once a suitable location has been found, attach the Remote Alarm Module using the screws provided, or screws suited to the material. 2) Connect the interconnecting cable to the module and Hy-Lite as shown. The Hy-Lite powers and signals the remote, no other connections are necessary.

A Hy-Lite Transformer should be dedicated to the system, and multi-Hy-Lite power configurations are not recommended. Refer to the Hy-Lite Installation & Operation brochure for information on Hy-Lite installation. The remote alarm module was designed for areas away from extreme moisture or splashing. Do NOT install outdoors. If the enclosure should become wet, dry promptly to avoid water entering at the enclosure/mounting plate seam.

Hydro-Check Systems, Inc

5931 Sea Lion Place, Suite 100, Carlsbad, CA 92008 Voice: 760-930-1924 Fax: 760-930-1934

www.hydrocheck.com